

Operation Manual

(MINI-450 & MINI-750)

Please read the manual carefully before you install the turbine.

Notifications for installation

Note: Operation rules taking MINI-450 wind turbine as example, user can refer to these rules for MINI-750.

1. Attentions for installation

- (1) Install the wind turbine on a day without the wind and the rain.
- (2) The installation and maintenance of wind turbine should be directed by the professional man or contacting dealers.
- (3) Pay attention to following items in use of controller of wind turbine
 - To prevent the accident, don't place this controller in area where is easily attacked by the water or in moister area.
 - Layman is not allowed to open the enclosure.
 - Keep this controller far away the hot air heater or other hot sources.
 - Prevent any liquid into the controller.
 - Never put this controller in the area where vibrates intensively.
 - The brake switch is only suitable for installation and maintenance.
 - The connections or parts marked with \triangle is very important in safety, so to replace or connect such these connections or parts should be done by the professional man, otherwise, the safety of product will be impaired for improper maintenance.
 - The purpose of brake switch in the controller panel: before installing the wind turbine, the rotor of wind wheel should be in the braking state, so as to guarantee the safety of installer.
- (4) Prior to installing the wind turbine, mount the lightning protection facilities according to the requirements.

2. Selection of site

The site of wind turbine plays a crucial role for prospective output capacity of wind turbine. Meanwhile, the site is directly relevant to the design or type of wind turbine. If unfamiliar with the wind energy system, user can consult the expert in wind energy.

Following technical principles are provided for customers in selecting the site of wind turbine.

- (1) As shown in wind energy formula $E = 1/2 \rho v^3 A$, the wind energy varies directly proportional to air density, impeller swept area, cub of wind speed, this formula expresses that the increase of wind speed brings more wind energy, e.g. if the wind speed is increased by one time, the wind energy will rise by 8 times. The methods for improving the wind speed as follows: one is to select the site where has big annual average wind speed, the other methods is to install the wind turbine in the proper area where is located as high as possible in safety height.
- (2) Upper site of dominating wind has no tree taller than 8m within 100m toward upper drift, and no house or wall higher than 3m within 30~35m.
- (3) Select the site where is quite flat land, low hypsographic feature in the prevailing wind direction, few obstacles, to reduce the intensity of turbulence
- (4) Select the site with rich and richer wind energy source where the terrain is helpful for speed increase or no obstacle to the air stream.
- (5) Never choose heavy hail, thunderstorm and earthquake-prone area.
- (6) The selected site should give facilities for customers to view the wind turbine, its land should be firm, so as to guarantee mounted wind turbine is fixed reliably.
- (7) The installation of wind turbine must conform to the local and national laws and regulations.

Preparation for installation

1. Check accessories in the packing case

Check off the accessories with the packing list in the packing case to ensure smooth installation

Packing list of MINI-450 wind turbine

No.	Part Name	Quantity
1	Generator body	1
2	Rotor Shaft	1
3	Hub	1
4	Blades	3
5	M8*30 Screw	9
6	Φ8 Flat Washer	9
7	M8 Anti-Loosening Nut	9
8	Nose Cone	1
9	M6*45 Screw	1
10	Φ 6 Flat Washer	1
11	M16*15	1
12	M16 Nut	1
13	Φ16 Spring Pad	1
14	M8*15 Screw	4
15	Φ8 Flat Washer	4
16	M8*15 Nu	4
17	Cable Connector	1
18	Yaw Shaft	1

2. Requirements for tower foundation

The supporting structure for wind turbine adopts guyed Tower tube structure, therefore, the tower tube base and guy base should take the cement or pasting rock as the foundation, as shown in fig. 1, meanwhile, mount the lightning protection facilities according to the requirements.

3. Tower tube

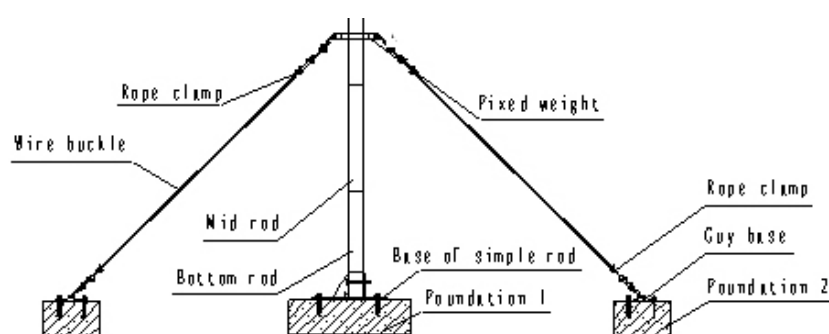

Fig. 1 Installation of wind turbine

The tower tube for installing the wind turbine must meet the following requirements:

- (1) The max horizontal force of tower tube required by MINI-450 wind turbine should be 500N, therefore, the tower tube should be competent for bearing the load of wind.
- (2) According to the situation of wind resource, the height of tower tube is 5~8m in available.
- (3) It is suggested that the seamless steel tube given anticorrosion treatment should be used as the tower tube, the base of tower tube should have perfect road adherence, the connection between tower tube base and tower tube should be made with the hinge and bolt, to take the convenience for installation and maintenance.

4. Guy wire

According to the installation height of wind turbine, the guy wire of 1 to 2 layers should be chosen, and 3 pieces of every layer should be available, wire rope of 4mm diameter given anticorrosion and antirust treatment should be used, its performance should be in accordance with the national standard.

5. cable

To reduce the electric loss of connection circuit of wind turbine, with the distance from the wind turbine to the controller, it is suggested that the current density of cable conductor should be $\leq 6A/mm^2$, and following cable conductors of different diameters should be selected.

Sectional area of 12V system cable conductor (mm²)	6	8	16
Sectional area of 24V system cable conductor (mm²)	4	6	10
Sectional area of 36V system cable conductor (mm²)	4	6	10
Sectional area of 48V system cable conductor (mm²)	4	6	10

Mounting methods

- (1) Fix the base of simple rod on the tower base 1, keep the plane of tower tube base at level (Fig. 2)
- (2) Put the cable through base of simple rod, tighten the top rod, mid rod and bottom rod in order corresponding to the top nut, while, let the cable pass through, place the bottom of bottom rod into the base of simple rod, loosely connect the bottom rod with the base of simple rod with the bolt. (Fig. 3)
- (3) Mount wind turbine well and fix it at the top rod.

(4) Mount the fixed weight at a distance of 4m from the bottom of rod, and fix it with the bolt, put one end of wire rope into the hole of fixed weight and fasten it with the rope clamp, as shown in fig.4. and let the other of wire rope through the ground puller, as shown in fig.5.

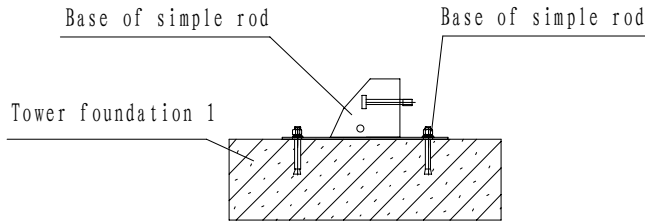

Fig. 2

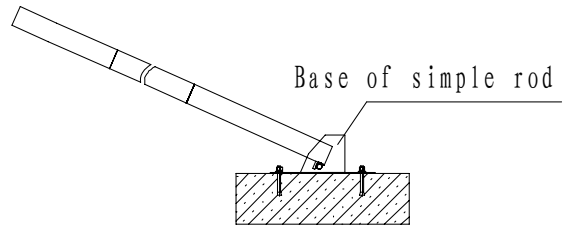

Fig. 3

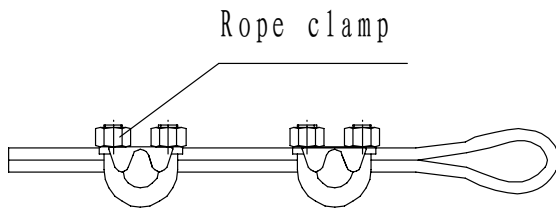

Fig 4

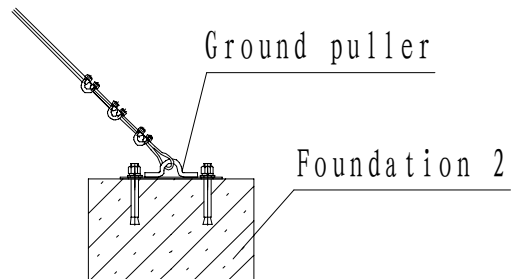

Fig5

(5) All exposed parts of simple rod should be given three-prevention treatment, to prevent the corrosion and rust.

2. Installation of assembly of wind turbine

(1) According to the weight of simple rod and placing installation of controller and battery, prepare proper three-core cable in length and conductor sectional area,

peel one appreciate section at both ends of cable, then peel off three conductors of one end of cable for insulation, connect the three conductors of the other of cable with the $\phi 6$ lug, and wrap the insulation, and wind three lugs with the nylon tape and short them.

(2) Connect three peeled conductors of cable one end with the connector of three outgoing wires of assembly of wind turbine.

(3) Let $\phi 4$ iron wire pass through the bottom of simple rod, lead it out from the top end of simple rod, at last, make the cable out of the simple rod.

(4) Mount the assembly of wind turbine to the top of simple rod, and fasten it with four M8×20 bolts at a twisting force of 6.5~10 N·m.

(5) Fix three horizontal fan blades in six inner holes at the connection between fan blade and flange, fix 3 M8×30 bolts to 3 outer holes at the connection between fan and flange at a twisting force of 6.5~10 N·m, thus, a wind wheel rotor is formed.

(6) Put the rotor of wind wheel over the cone axis of rotation axis of three-phase permanent-magnet AC generator, fix them with M16 nut at a twisting force of 40~50 N·m.

(7) Fix the cowling into the thread hole of rotation axis center with M6×45 hex screw at a twisting force of 4.5~6.5 N·m., and cork with the plug.

(8) In accordance with voltage class of wind turbine and quantity of battery jars, the storage battery is connected, the positive and negative conductors of battery should be led out (with $\phi 6$ lug, insulated well).

(9) Connect three conductors of phases U, V and W, positive and negative conductors of battery as well as positive and negative conductors (with $\phi 6$ lug, insulated well)of load to the corresponding terminals of controller, and fix them.

Attention: The abovementioned fasteners must be firm and reliable, otherwise, it will loose for vibration, and this results in damage of wind turbine.

3、 Erect simple rod

- (1) Pull the simple rod up, let it in the vertical position, tighten two bolts at the base of simple rod. There should be enough men to pull the simple rod.
- (2) Fix ground puller with the pre-embedded anchor bolt on the foundation 2, ensure tower tube lies in the ground and is inclined at an angle of 90°. Tighten the guyed cables uniformly, fix them with the rope clamp, the position must be distributed uniformly at the circle.

Warning: In installing, the tower tube must be vertical to ground, only that, the wind turbine can be horizontal, otherwise, this would lead to abnormal run of wind turbine.

Electric schematic diagram, wiring methods, installation and debugging methods

1. Electric schematic diagram and wiring methods

Please wire according to the following electric schematic diagram, guarantee accurate wiring and firm and reliability connection of battery bank.

According to the load character, electric wiring of wind turbine can be divided into two types, its relative system wiring schematic diagram as shown in Fig.6 and Fig.7.

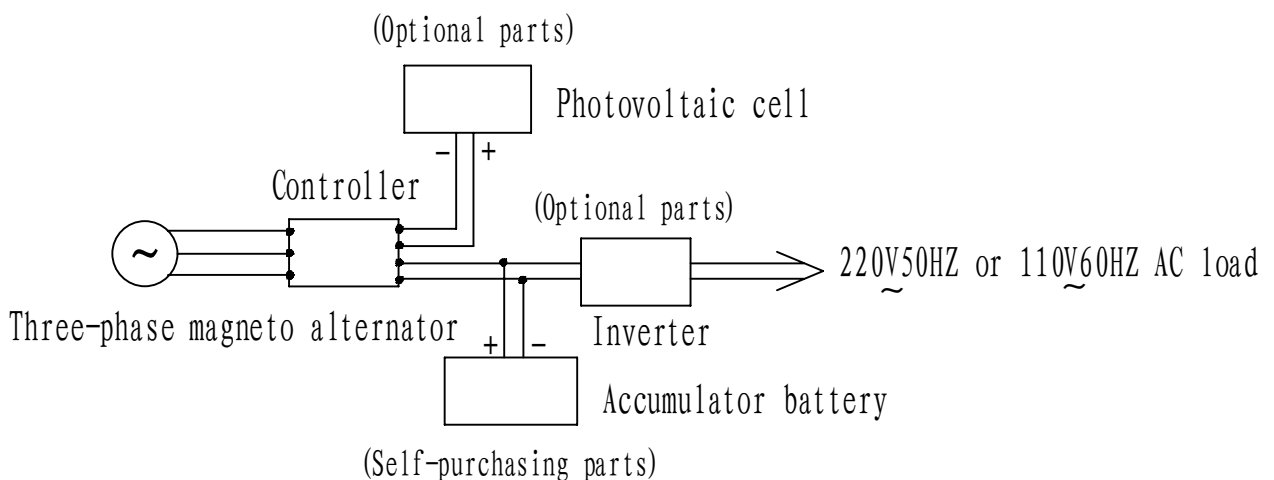
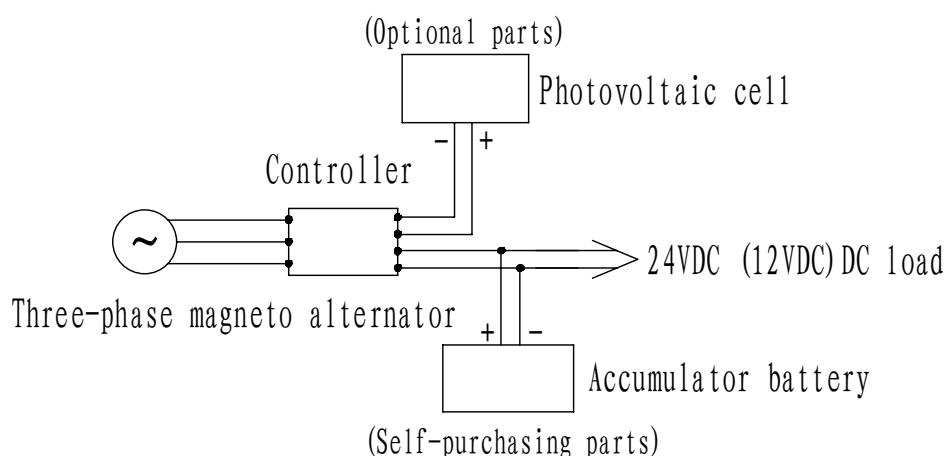

Fig.6

**Fig.7**

2. Installation and debugging of wind turbine

(1) Before connecting the three cables of wind turbine with the terminal block of controller panel, please check if the operation of three-phase magneto alternator is in normal condition, rotate the wind wheel rotor of wind driven generator, measure any two cable terminals of the three with alternating voltage of multimeter, there should have AC voltage displayed.

(2) Select corresponding electric schematic diagram according to the user load property, i.e. DC load or AC load, then wire accurately according to the terminal description on panel, please pay special attention to the controller, battery bank and photovoltaic battery pack, voltage class of inverter should be accordant, and the polarity should never be inversely connected, the wiring should be firm and reliable. After everything is normal, set the tower pipe vertically, and dial the brake switch on the panel to position "BRAKE".

(3) After the wind wheel rotor starts, the wind indicator lamp of control should go on.

(4) Selection of capacity of battery bank should be on the basis of guarantee of continuous power supply, and select according to the daily power consumption of user, daily energy output of wind turbine and local continuous windless period. Anyhow, daily energy output of wind turbine should be larger than the max storage capacity of battery bank, and the min storage capacity of battery bank should be larger than the daily power consumption of user. The actual storage

capacity also depends on the length of windless period. If the capacity is too large, the storage battery will be in under-charge state often, this would shorten its service life; if the capacity is too small, the power supply would be interrupted, and the storage battery may be in over-discharged state often, this also would shorten its service life, and waste the wind energy.

(5) When applying wind-solar hybrid power supply system, selection of its solar panel should be according to the local annual mean sunshine duration, daily mean radiation quantity, latitude, load, hours of use, determined by calculating.

Warning: quality of battery bank determines the 酥皮蓬理应 capacity of wind turbine system, please pay attention to maintenance regularly, and change it immediately once it is damaged.

Notice:

(1) When wiring in the photovoltaic battery and storage battery, please put stress on proper connection of the polarity, rated voltage should be 12V_{DC} (24V_{DC}), otherwise, the equipment would be damaged.

(2) External wiring sequence of controller is the three input lines of wind machine, then is the storage battery, the last is the solar input line.

Maintenance of wind turbine

1. Check or clean and lubricate all the rotational parts regularly.
2. Check all the fasteners or connectors, wire ropes and riggings within 12 months of operation, tighten them and make rust-proofing treatment.
3. After every one year of operation, ask for professional worker to maintain the bearing of wind driven generator for one time.
4. Clean, remove rust and paint all the components of the machine for one time every two years in average.
5. After rainstorm, please check the tensile force and screwing force of cable rope.
6. Maintenance of battery bank should be carried out according to its operating manual.

Specification

Model	MINI-450	MINI-750
Rated Power(W)	450W	750W
Max. Power(W)	600W	900W
Startup wind speed	2.3m/s	
Cut-In wind speed	3m/s	
Rated wind speed	12m/s	12m/s
Safety wind speed	35m/s	40m/s
Rated Voltage (V)	12 / 24V / 48	24 / 48V
Rotor Diameter	1.4m	1.8m
Number Of Blade	3	
Blade material	Fiberglass reinforced composite	
Generator Type	Permanent magnet brushless	
Charge controller	Hybrid solar-wind charge controller, LCD display, PWM Charger	
Over-speed protection	Stall Control Dump Load Manual Electromagnetic Brake	
Battery Capacity (AH)	100A/12v*2 60/12V*4 for 48V system	150/12V*2 80ah*4 for 48V system
Solar Power (W)	150	250
Packing Size (MM)	1165*445*200mm	1165*445*200mm
Gross Weight (KG)	23	30.5

2、MINI-450 power curve

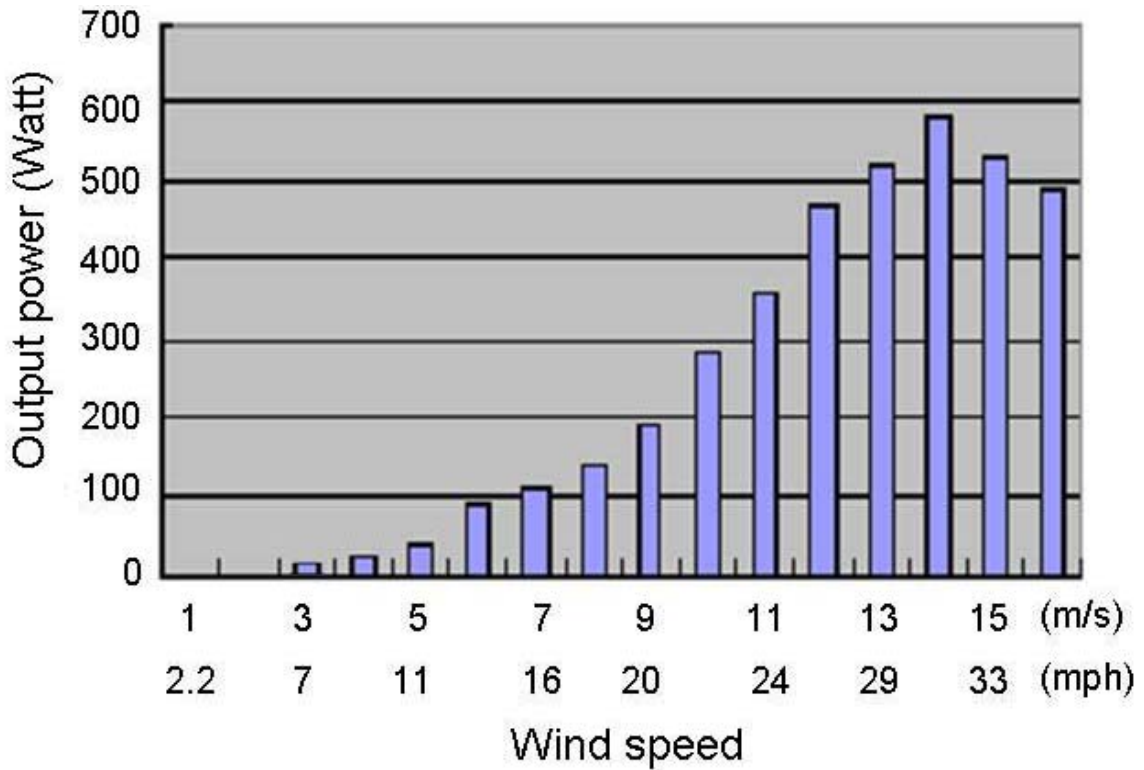

3、MINI-750 monthly generated output

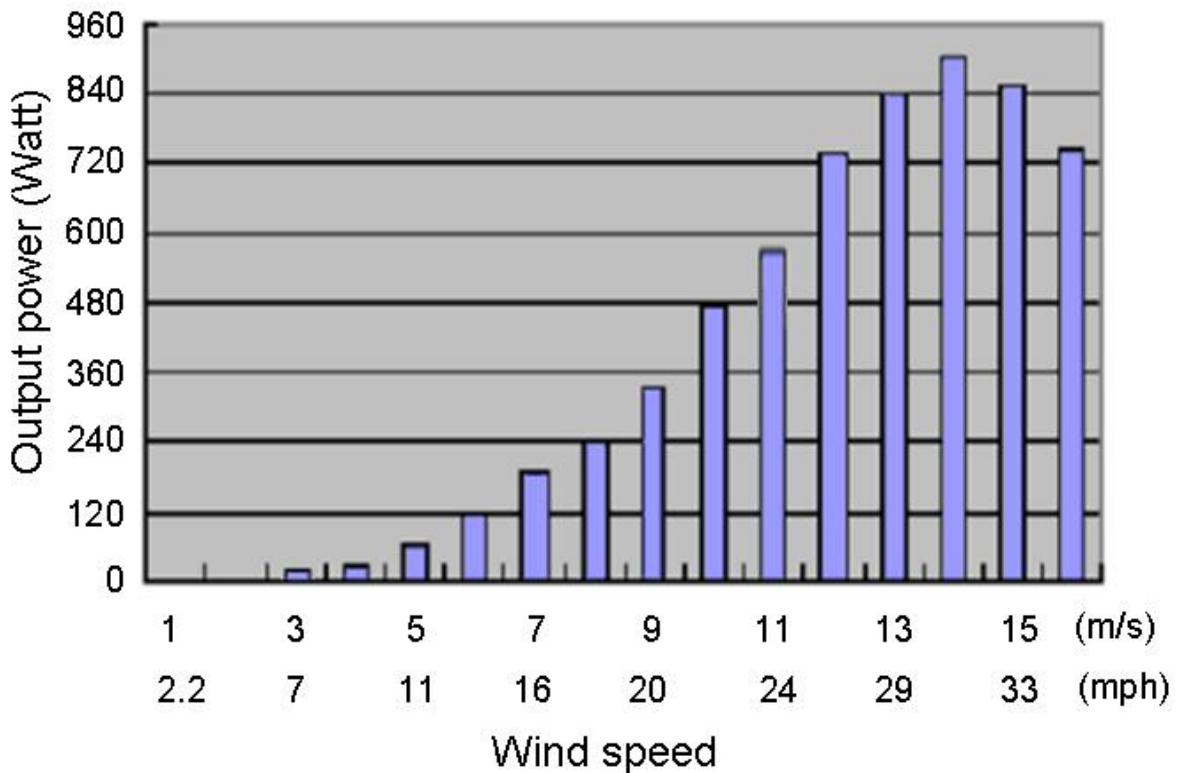

Failure Judgment and Elimination

Failure	Cause	Elimination
Sever vibration of wind machine	<ol style="list-style-type: none"> 1. The wire rope becomes loose 2. Blade set bolt becomes loose 3. There is ice on the blade surface, and cause unbalance 	<ol style="list-style-type: none"> 1. Align and tighten the wire rope 2. Tighten the loose part 3. Clear away the ice
Insensitive Direction regulation	<ol style="list-style-type: none"> 1. regulating bearing is damaged 2. Tail vane is damaged by outside force 	<ol style="list-style-type: none"> 1. change the bearing 2. Repair or change the tail vane
Abnormal noise	<ol style="list-style-type: none"> 1. The fastening part of wind driven generator become loos 2. Generator bearing become loose from the pedestal 3. Generator bearing is damaged 	<ol style="list-style-type: none"> 1. Lay down the wind driven generator, check each fastening part, and take loose proof measures 2. Check the part, repair and eliminate the trouble 3. Change the bearing
Low output voltage of generator	<ol style="list-style-type: none"> 1. Low rotating speed of motor 2. Slip ring of power transmission, bad contact of connection point in output line. 3. Long LV power transmission line, wire diameter is too thin 4. Wind wheel becomes loose 5. Cowling become loose or fall off 	<ol style="list-style-type: none"> 1. Check if the generator bearing is damaged 2. Clear the slip ring and connection point, or adjust the tensile force of carbon brush pressure spring, reduce the contact resistance 3. Shorten the circuitry or thicken the wire diameter, reduce line loss 4. Tighten, firm reliably 5. Firm or reassemble
AC output of motor is normal, but no DC output	<ol style="list-style-type: none"> 1. Output line has open-circuit 2. Controller is damaged 	<ol style="list-style-type: none"> 1. Check the broken part and put through 2. Change
Output capacity of battery bank is not enough	<ol style="list-style-type: none"> 1. Output voltage of generator is too low, or the generator is failed to generate power 2. Binding post of battery bank is etched, or has bad electric conduction 3. Battery bank is out of service 	<ol style="list-style-type: none"> 1. Check and eliminate according the above items 2. Adjust the connection part to get a fine contact, tighten reliably, coat some preservative oil 3. Change the battery bank